

10/22[®]

TARGET BARREL REPLACEMENT INSTALLATION INSTRUCTIONS

An on-line video demonstrating the disassembly and reassembly of the Ruger[®] 10/22[®] rifles can be viewed by visiting www.ruger.com/resources/videos and then selecting “Ruger Tech Tips.”

STOCK REMOVAL

1. With the rifle pointing in a safe direction, remove the magazine, open the bolt and visually make certain there is not a cartridge in the chamber. Allow the bolt to close. The rear sight leaf should be down, and the hammer should be cocked.
2. For Carbine Model 10/22[®] Rifles, loosen the barrel band screw (see Figure 1a) and remove the barrel band (see Figure 1b).

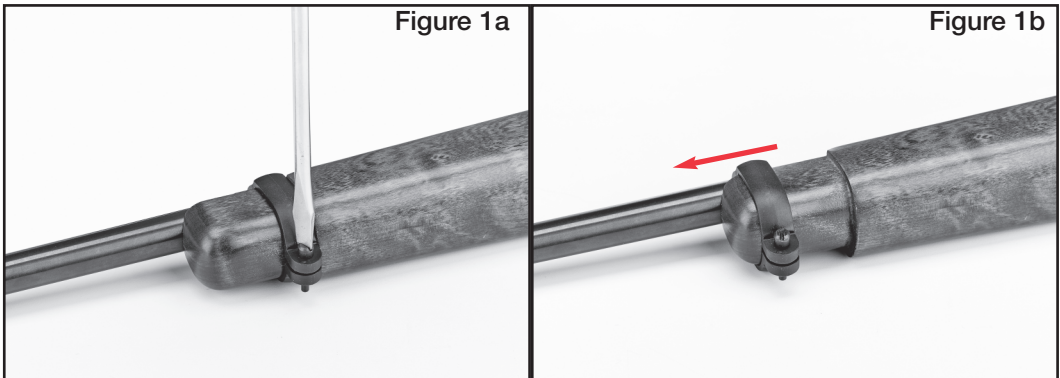

3. Loosen (do not remove) the take-down screw. (See Figures 2a & 2b.)

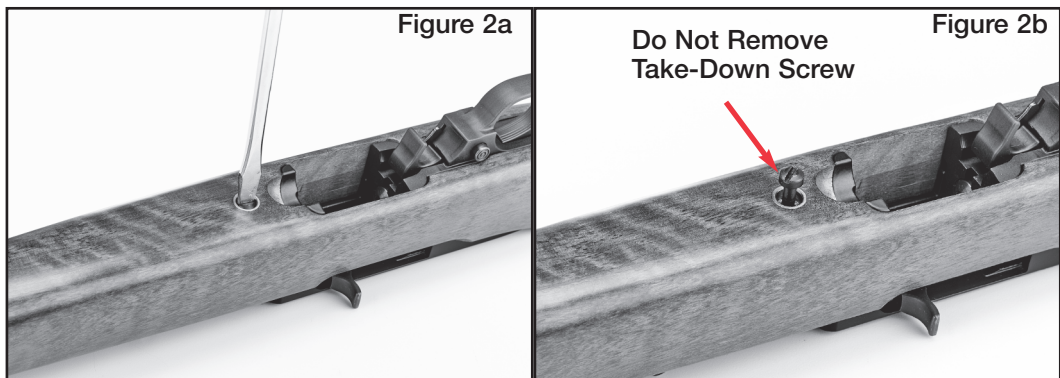

4. Position the safety so an equal amount of the button is exposed on each side (see Figure 3). If the safety is not in the middle when the barrel-receiver assembly is lifted out of the stock, the stock will be damaged.

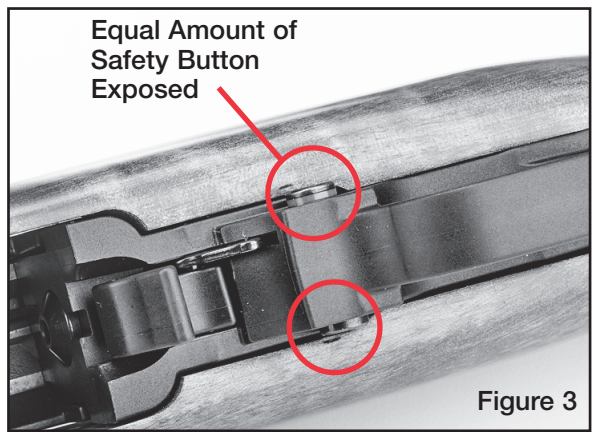

5. Swing the barrel-receiver assembly upward and away from the forearm of the stock (see Figure 4). Be careful the two receiver cross pins and bolt stop pin do not fall out (see Figure 4a).

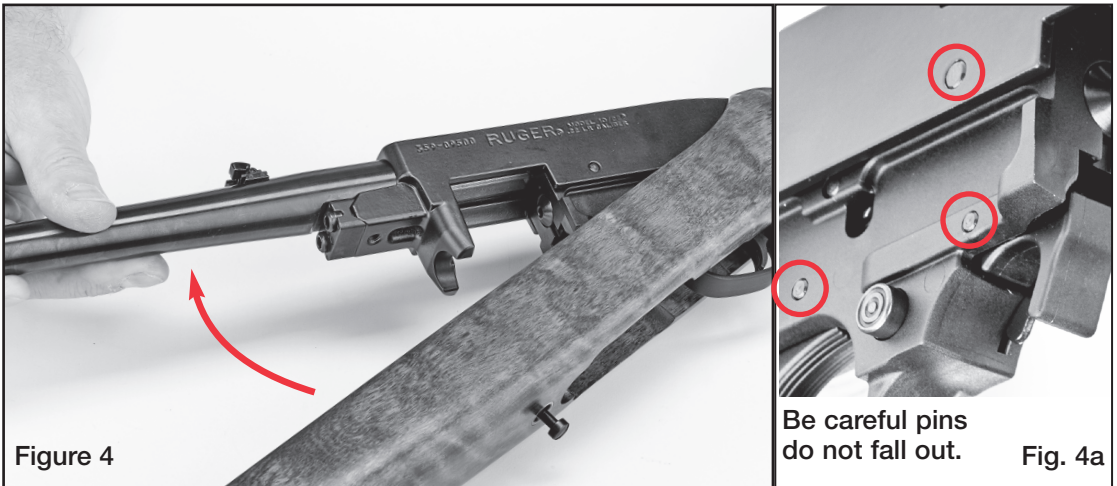

BARREL REMOVAL

1. Use a 5/32" Allen wrench to remove the two barrel retainer screws from the barrel retainer v-block (see Figure 5).

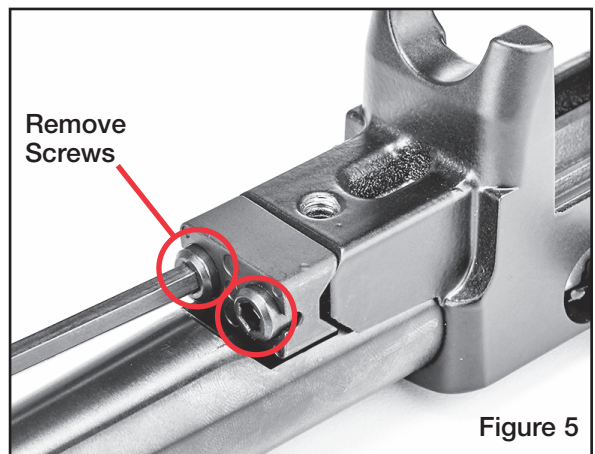

2. Remove the barrel retainer v-block and the barrel (see Figure 6).

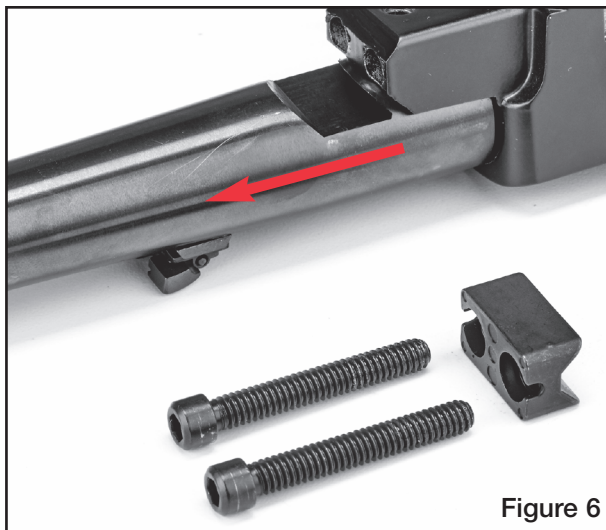

Figure 6

BARREL INSTALLATION

1. Install the target barrel (see Figure 7).

Note: You will have to tap the muzzle of the barrel with a non-marring hammer in order for the barrel to fully seat into the receiver.

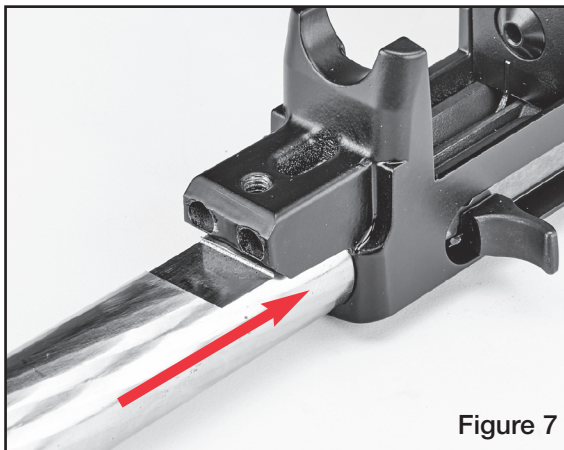

Figure 7

2. Install the v-block and retainer screws (see Figure 8). Hand-tighten the screws as tight as possible.

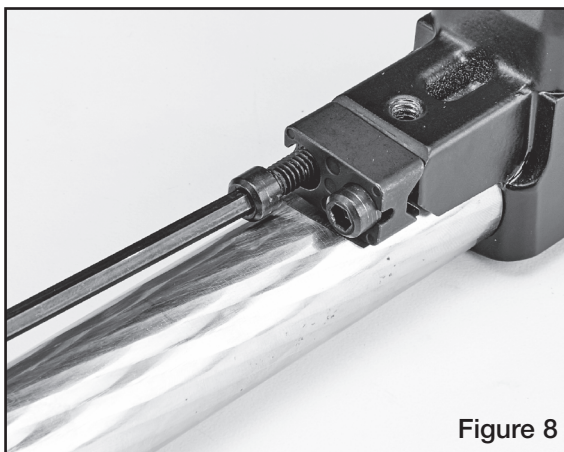
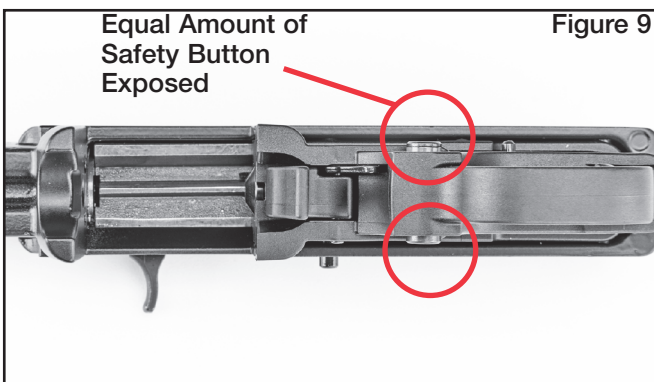
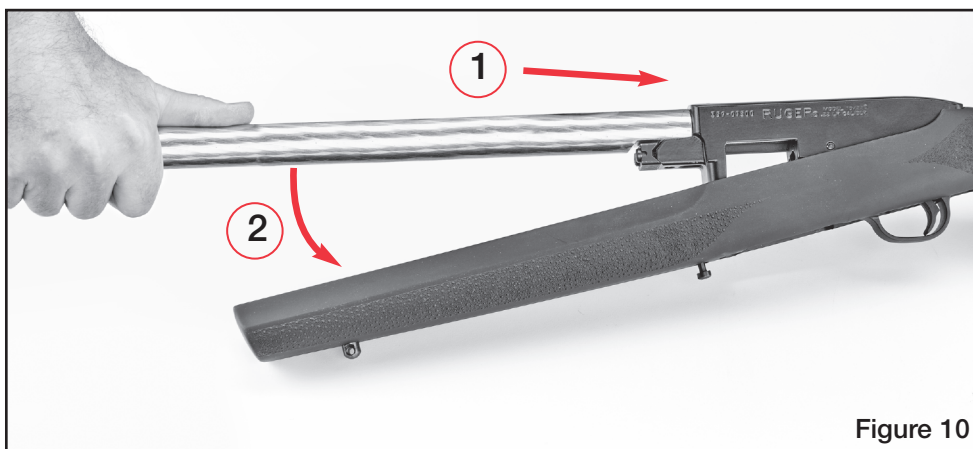

Figure 8

3. Position the safety so an equal amount of the button is exposed on each side (see Figure 9).



4. Insert the barrel-receiver assembly into a target stock by guiding the rear portion of the assembly into the stock and then lowering the forward portion into position (see Figure 10).



5. Hand-tighten the take-down screw as tight as possible (see Figure 11).

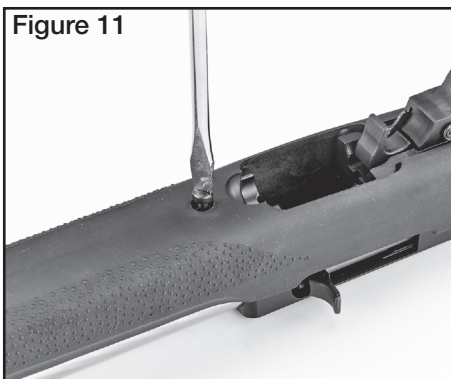

If the rifle does not function properly after installing the new barrel, repeat the the steps above or call Ruger Customer Service at 336-949-5200 for further assistance.